

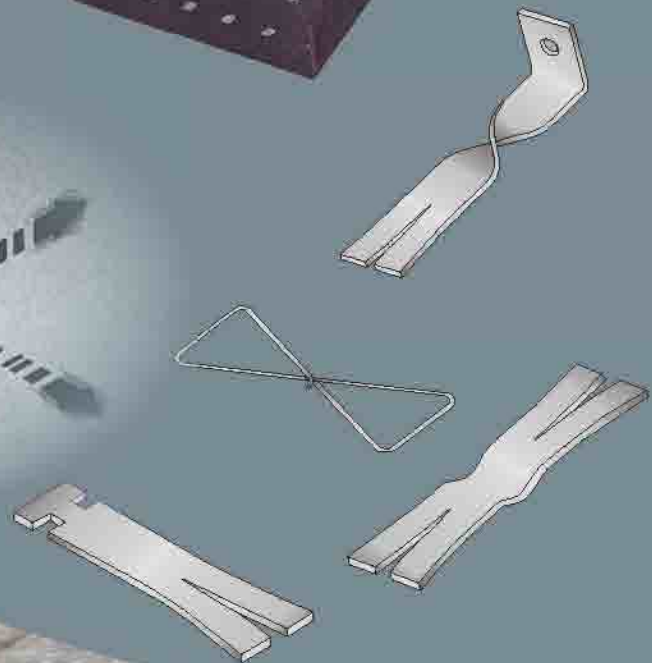

S F S P

STEEL LINTELS & BLOCK WORK ACCESSORIES

STEEL LINTELS
&
BLOCK WORK
ACCESSORIES

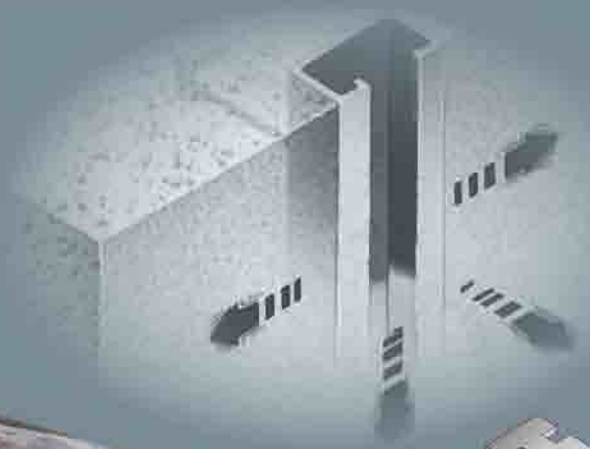

Introduction

SFSP designs, and manufactures, quality building products. We are committed to excellence in product development and customer service.

For almost 15 years **SFSP** has been at the forefront of the design, development and manufacture of galvanized-and stainless steel systems for the building industry.

Steel lintels, cramps and ties are fabricated to meet specific design requirements in the most economic way and may be called off as required on site against an agreed schedule.

A full technical service is offered by **SFSP** to assist customers in the correct selection of standard components and the design of cramps and ties to meet special requirements. **SFSP** is a leader in the building products industry and is continually developing and improving existing products, as well as designing new products to meet the requirements of a changing industry.

For the fullest information on building products contact our technical department or appointed sales offices. <http://www.unitech-ikk.com>

Uni Metal "Steel Lintels" a product of:

Specialized Factory for Steel Products (SFSP)

Tel: +966 2 6374482 Fax: +966 2 6361963

E-mail : sfsp@unitech-ikk.com

SIGMA Factory for Steel Products (SFSP)

Tel: +971 4 3402637 Fax: +971 4 3402636

E-mail : sigma@unitech-ikk.com

Steel Lintels



Specifications:

UNI-METAL lintels are manufactured according to the specifications laid down in BS5977:part 2:1983.

UNI-METAL lintels are made from:

- Pre-galvanized steel complying with:
 - BS 2989: steel grade Z2, zinc coating type G275.
 - ASTM A527 – G90
 - DIN EN 10147
- Mild steel sheet complying with
 - BS 1449: sec 1.1 to 1.15
 - ASTM A36
 then hot-dip galvanized in accordance with.
 - BS 729
 - ASTM A123
 - NF A91121-A91122
 - DIN 50976
- Steel paint finish
- Powder coated finish
- Stainless steel complying with:
 - BS 1449: part 2
 - AISI 304 , A2
 - DIN , material no. 1.4301
 - EN 10088.

Installation:

- 20 cm end bearing should be allowed at each side.
- Damaged lintels should not be used.

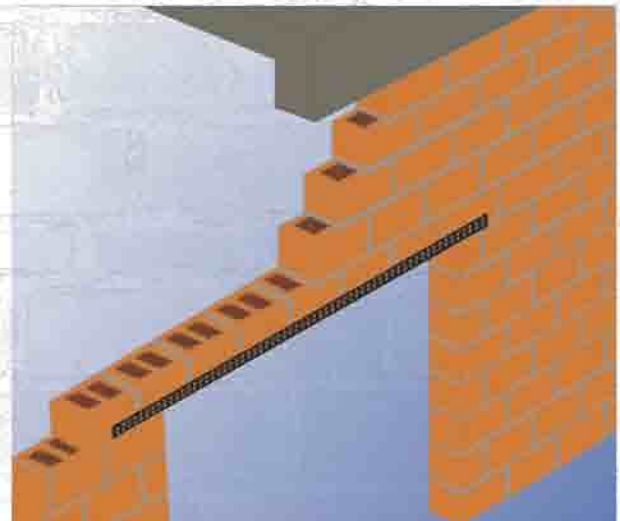

Channel Lintels For Solid Walls

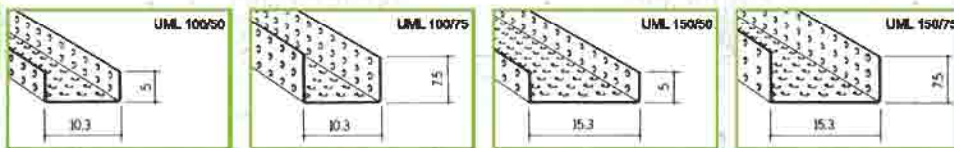

Lintel Type	UML 100/50			UML 100/75	UML 150/50			UML 150/75
Lintel Code	UML 100/50-20	UML 100/50-30	UML 100/50-40	UML 100/75-40	UML 150/50-20	UML 150/50-30	UML 150/50-40	UML 150/75-40
Sheet Thickness(mm)	2.0	3.0	4.0	4.0	2.0	3.0	4.0	4.0
Length in meters	Uniformly distributed safe working load in (KN)							
0.90-1.20	5.5	9.3	12.4	17.0	4.8	8.8	13.2	17.0
1.30-1.50	4.2	6.0	6.8	12.8	3.7	6.0	7.1	12.8
1.60-1.80	-	4.0	5.0	10.4	-	4.4	5.8	10.4
1.90-2.10	-	-	3.6	9.2	-	-	4.0	9.2
2.20-2.40	-	-	2.7	7.0	-	-	3.1	7.0

Channel Lintels For Solid Walls

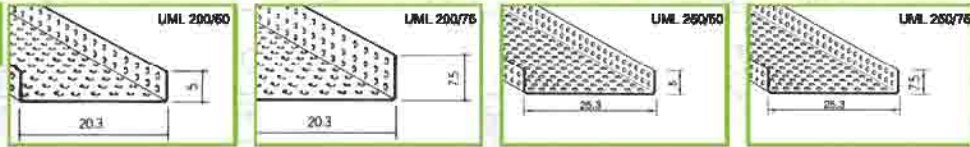

Lintel Type	UML 200/50			UML 200/75	UML 250/50			UML 250/75
Lintel Code	UML 200/50-20	UML 200/50-30	UML 200/50-40	UML 200/75-40	UML 250/50-20	UML 250/50-30	UML 250/50-40	UML 250/75-40
Sheet Thickness (mm)	2.0	3.0	4.0	4.0	2.0	3.0	4.0	4.0
Length in meters	Uniformly distributed safe working load in (KN)							
0.90-1.20	6.2	8.9	12.7	17.0	6.2	8.9	12.7	17.0
1.30-1.50	4.8	6.0	7.2	12.8	4.8	6.1	7.2	12.8
1.60-1.80	-	4.4	5.9	10.4	-	4.4	5.9	10.4
1.90-2.10	-	-	4.1	9.2	-	-	4.1	9.2
2.20-2.40	-	-	3.2	7.0	-	-	3.2	7.0

Lintel Brackets

Code	Dimensions (mm)				To suit lintel type	No. & Diameter of anchors
	A	B	C	S		
LBR 100	100	150	150	5	UML 100	3 M 8 x 80
LBR 150	150	150	150	5	UML 150	4 M 8 x 80
LBR 200	200	200	150	6	UML 200	3 M 10 x 80
LBR 250	250	200	150	6	UML 250	4 M 10 x 80

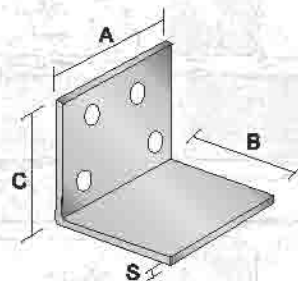

INSTALLATION

Here is a typical installation of Uni-metal steel lintel which abuts to a concrete column. A Uni-metal bracket is used to facilitate one end bearing



Level is obtained and bracket is fixed to column using bolt fixings

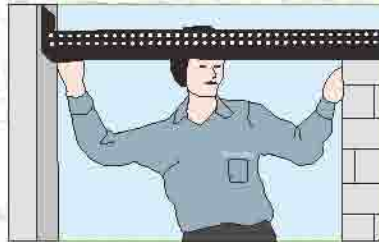

Lintel is placed in position

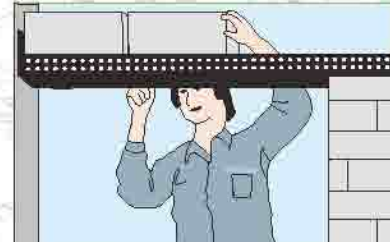

Continuation of blockwork can be carried out immediately

Total installation time 6 minutes.

The time-saving using a Uni-metal lintel with two wall end bearings, i.e. without the need of brackets would have been much greater.

CONCRETE CAST - INSITE INSTALLATION



Vertical frame work erected, end secured and horizontal level taken



Commencement of lintel formwork



Continuation of formwork

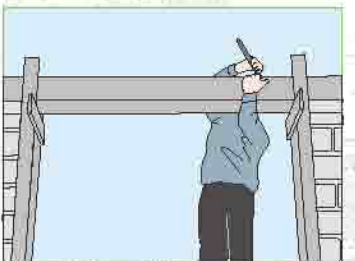

Completion of formwork

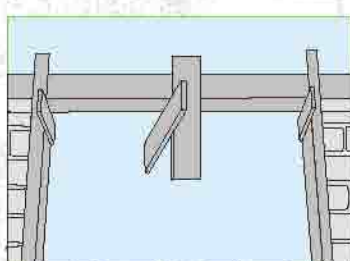

Completion of lintel after steel reinforcement and pouring of concrete

IN THE TIME TAKEN TO INSTALL JUST ONE CONCRETE LINTEL, EIGHT UNI-METAL LINTELS COULD HAVE BEEN INSTALLED

Channel Sections

CCH Series

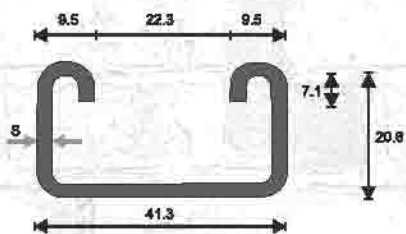
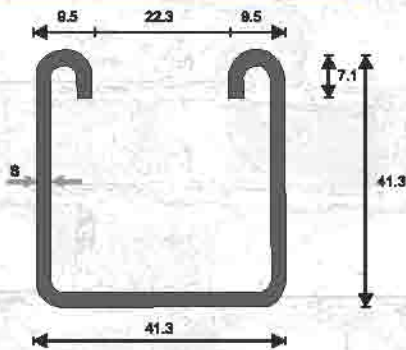

Finish	Thickness	Standard Length
Pre-galvanized	2.0 & 2.5mm	3m. & 6m.
Hot-dip galvanized	2.0 & 2.5mm	3m.
Stainless steel 304	2.0mm	2.44m.
Self color	2.0 & 2.5mm	3m. & 6m.

Code	Dimension	Material
CCH-210	21 x 41 x 2.0 mm	Pre-galvanized
CCH-220	21 x 41 x 2.5 mm	Pre-galvanized
CCH-410	41 x 41 x 2.0 mm	Pre-galvanized
CCH-420	41 x 41 x 2.5 mm	Pre-galvanized

RCH Series

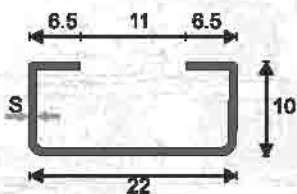

Standard finishes & lengths:

- Pre-galvanized, self color in 3 & 6m. lengths.
- Hot-dip galvanized in 3m. lengths
- Stainless steel 304 in 2.44m. length
- Shorter lengths are available upon request
- S=1.0, 1.25 and 1.5 mm

SCH Series

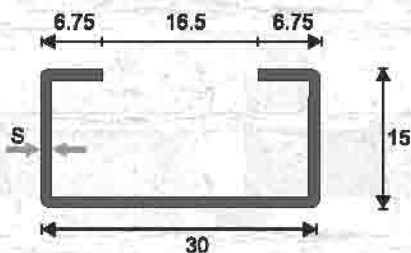

Standard finishes & lengths:

- Pre-galvanized self color in 3 & 6m. lengths.
- Hot-dip galvanized in 3m. lengths
- Stainless steel 304 in 2.44m. length
- Shorter lengths are available upon request
- S=1.0, 1.25 and 1.5 mm

DCH Series

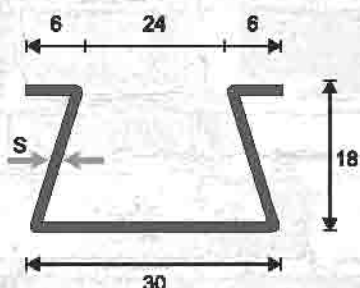

Standard finishes & lengths:

- Pre-galvanized, self color in 2.44m lengths.
- Hot-dip galvanized in 2.44m lengths
- Stainless steel 304 in 2.44m. lengths
- Shorter lengths are available upon request
- S=1.0, and 1.5 mm

Channels for casting into concrete are supplied with bonding lugs. These may take different forms according to the preferred channel and design requirements.

BLG 1 Fishtailed
Split and fishtailed strip welded to channel series: CCH/ SCH
tail: 20 x 2mm x 75mm

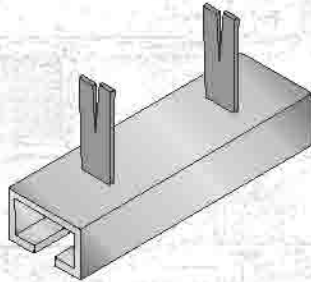

BLG 3 Gull wing.
Bent steel strip welded to channel series: CCH/RCH/SCH
wing: 20 x 2mm x 75mm.

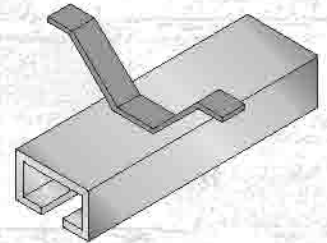

BLG 2 Wavy tail
Crimped strip welded to channel series: CCH/ SCH
tail: 20 x 2mm x 75mm

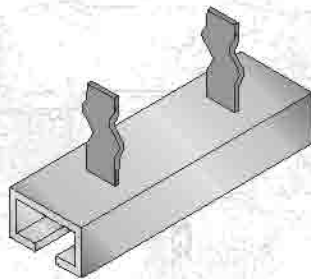

BLG 4 Formed tang
Once bent strip welded to channel Series: CCH/SCH.
Minimum two per channel.

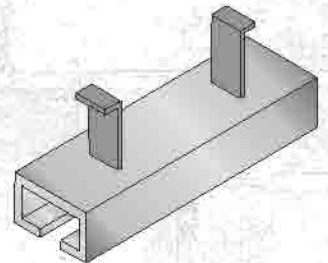

Channel series	Lug Spacing mm	Maximum Safe Working Load Per Bolt			
		Pullout (KN) 	Shear (KN) 	Longitudinal (KN) 	Edge Distance Minimum mm
CCH	250	6.0	7.0	2.5	50
	150	8.0	9.0	2.5	50
SCH	250	4.0	6.0	1.5	50

Note: Quoted safe working loads include a 3:1 safety factor and one for single bolt applications.

Face Fixing

Channels may be face-fixed using expanding bolts with plate washers (40 x 30 x 3mm). Channels are pre-drilled to requirement, centers and size of holes should be specified when ordering.

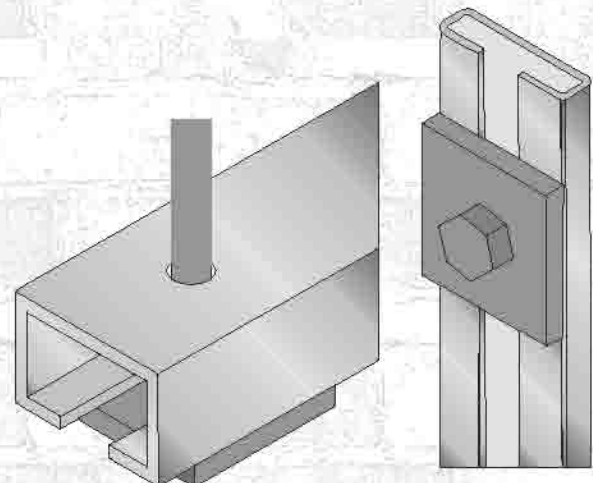

Cramps and Ties

Specifications:

UNI METAL cramps and ties are manufactured from:

- Pre-galvanized steel complying with:
 - BS 2989: steel grade Z2, zinc coating type G275.
 - ASTM A527-G90
 - DIN EN 10147
- Mild steel sheet complying with
 - BS 1449:sec. 1.1 to 1.15 (formerly BS 1449: part 1)
 - ASTM A36
 then hot-dip galvanized in accordance with
 - BS 729
 - ASTM A123
 - NF A91121-A91122
 - DIN 50967
- Mild steel wire to BS 1052: 1989 (1986). zinc plated after manufacture to BS 1706:1990 (1996).
- Mild steel wire to BS 1052: 1980 (1986) hot-dip galvanized after manufacture to BS 729: 1971 (1984)
- Mild steel wire to BS 1052: 1980 (1986) epoxy coated after manufacture.
- Stainless steel complying with:
 - for straps:
 - BS 1449:part 2
 - AISI 304 : A2
 - DIN , material no. 1.4301
 - EN 10088
 - for wires :
 - BS 1554:1990

Description:

A full range of ties and cramps is offered suitable for use in the construction of cavity walls and block facing.

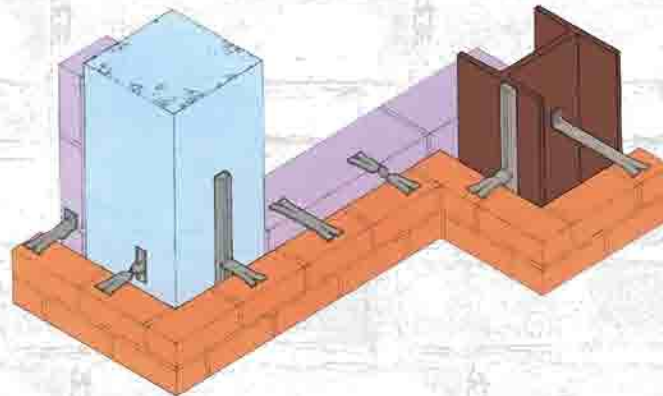

Tail End Options

The most common method of anchoring a tie to a slab facing, is by means of a round dowel into a drilled hole, split tangs on the tie may also be used. For bonding into brickwork the "Fishtailed" end is the traditional form.

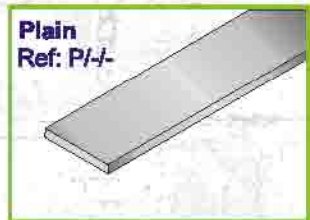
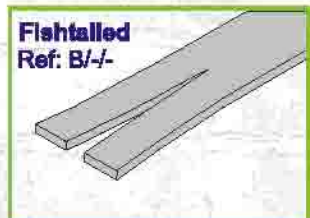
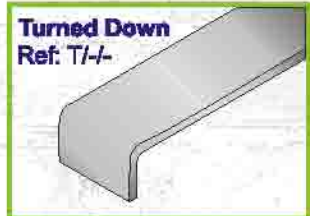
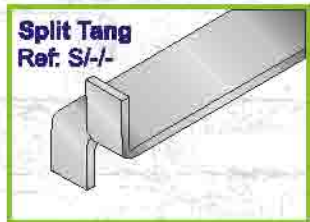

Shank Options

Shanks may be plain or may include a drip to stop the passage of moisture across the cavity.

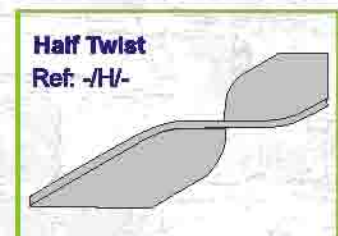
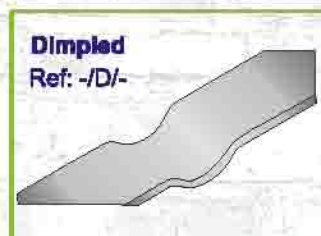
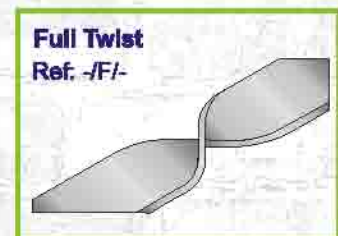
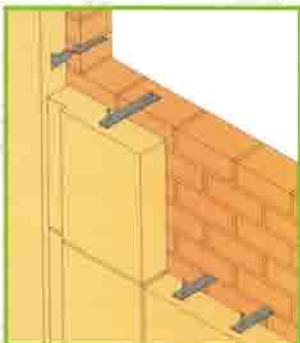



Head End Options

Tie ends may be profiled to fit standard channel sections which may be pre-set into concrete or surface fixed to any inner skin or structural ground.

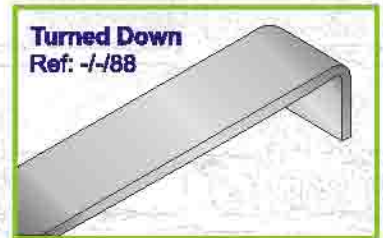
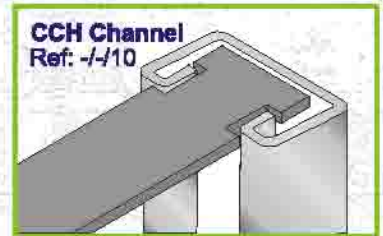
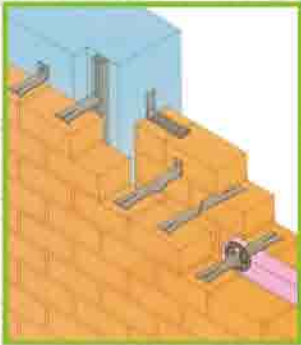

Reference Codes

Each tie will consist of a tail element, for attachment to the facing material, a shank element, and a head element, for attachment to the structure.

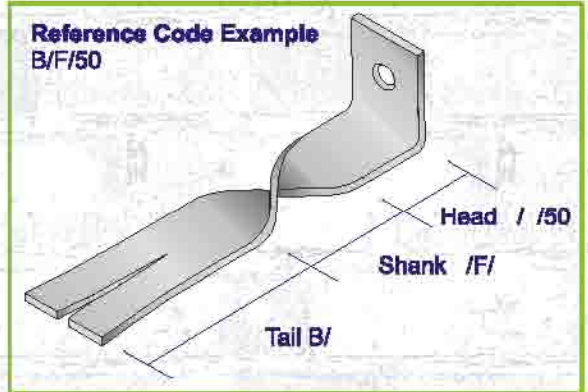

Dimensional Standards

Fixed dimensions.

When specifying ties certain set or minimum dimensions shall be followed, these are described as fixed dimensions and based on the limitations of material and the production processes.

Where a screw or bolt fixing is to be made a minimum length of 30mm is required.



Lengths

Lengths are generally measured to the extremity of the tie. For ties fitting into channels the specified length is measured to the shoulder of the tie:

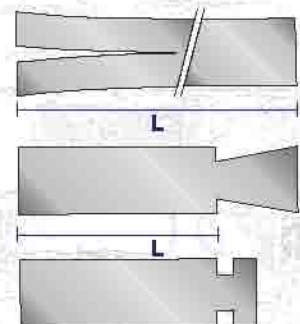

Brick Facing and Cavity Ties



		Dimensions - See Panel Below Lengths to suit cavity widths					
Reference Code	Description	Section Size(mm)	0-20 (mm)	15-45 (mm)	40-70 (mm)	65-70 (mm)	Position of Drip (min)mm
B/P/30	Brick facing tie	30 X 2.0	75	100	125	150	
B/D/30	Brick facing tie	30 X 2.0		100	125	150	20
B/F/30	Brick facing tie	30 X 2.0			125	150	30
B/P/21	Brick facing tie	30 X 2.0	75	100	125	150	
B/D/21	Brick facing tie	30 X 2.0		100	125	150	20
B/F/21	Brick facing tie	30 X 2.0		100	125	150	30
B/P/28	Brick facing tie	30 X 2.0	75	100	125	150	
B/D/28	Brick facing tie	30 X 2.0		100	125	150	20
B/F/28	Brick facing tie	30 X 2.0			125	150	30
B/P/36	Brick facing tie	30 X 2.0	75	100	125	150	
B/D/36	Brick facing tie	30 X 2.0		100	125	150	20
B/F/36	Brick facing tie	30 X 2.0			125	150	30
B/P/50	Brick facing tie	30 X 2.0	75	100	125	150	
B/D/50	Brick facing tie	30 X 2.0		100	125	150	25
B/F/50	Brick facing tie	30 X 2.0			125	150	35
B/P/99	Cavity wall tie	30 X 2.0	150	200	225	150	
B/D/99	Cavity wall tie	30 X 2.0	150	200	225	150	75
B/F/99	Cavity wall tie	30 X 2.0	150	200	225	150	75
C/C/30	Corrug strip	30.1.5	150	175	200	225	
C/C/50	Corrug. Anchor	30.2.0	150	175	200	225	
V/W/04	VEE Tie	Ø 4	75	100	125	150	



wire Ties

A range of cavity wall ties are available manufactured in accordance with BS 123: 1978. These are available in stainless steel, pre-galvanized or hot-dip galvanized steel, and to the dimensions shown.

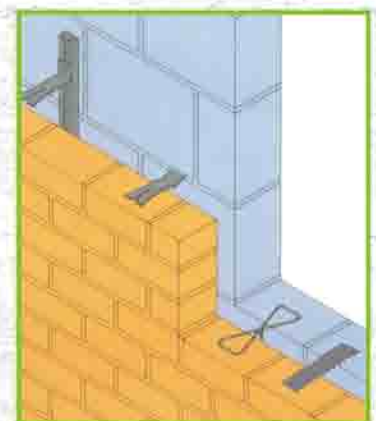
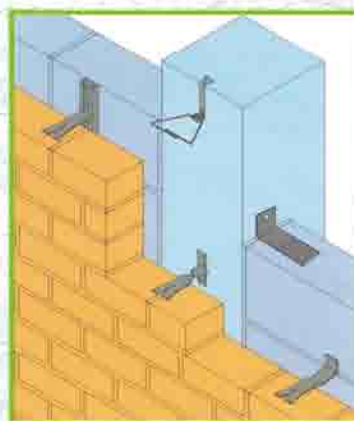

"Butterfly" tie
150mm x 75mm
200mm x 100mm
Both sizes available in Ø4 mm wire.

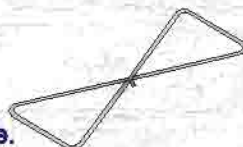

"Double-triangle" tie
150mm x 65mm
200mm x 65mm
Both sizes available in Ø4 mm wire.

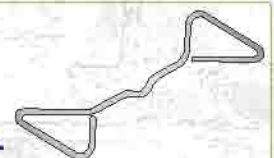

Slip Sliding Anchors

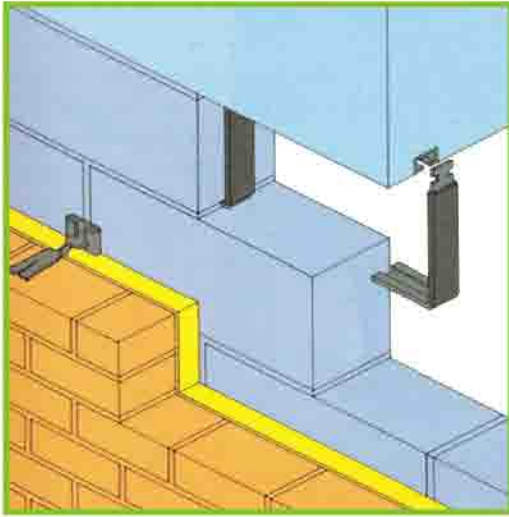

Sliding Anchors

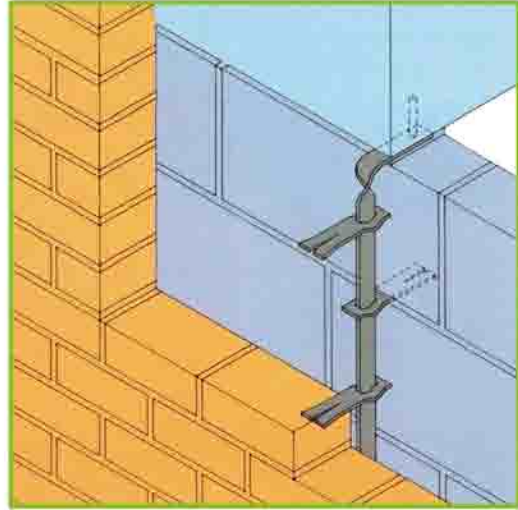

Sliding Anchors

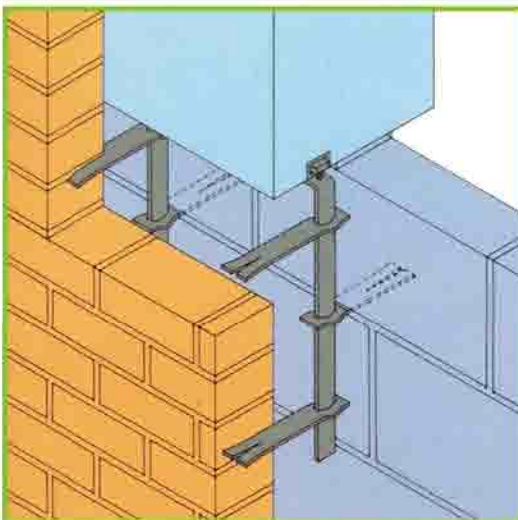

Sliding Ties

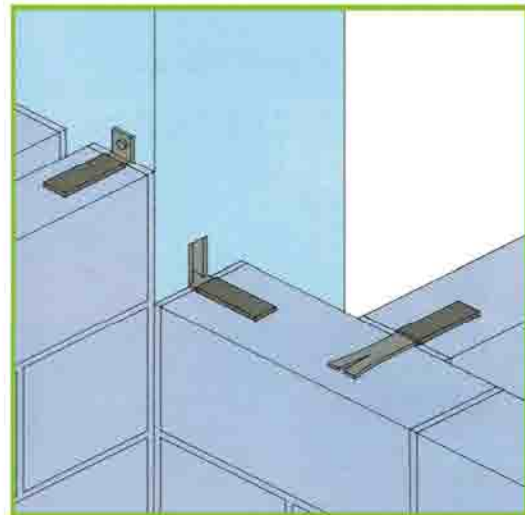

All illustrations, drawings and descriptive matter in this publication are of a generally informative nature only and do not form complete package of the specifications or description of the goods.
Most of the dimensions shown are nominal. **SFSP** can make modifications in specifications, design, materials or finishes as it deems necessary or desirable.

STEEL LINTELS & BLOCK WORK ACCESSORIES

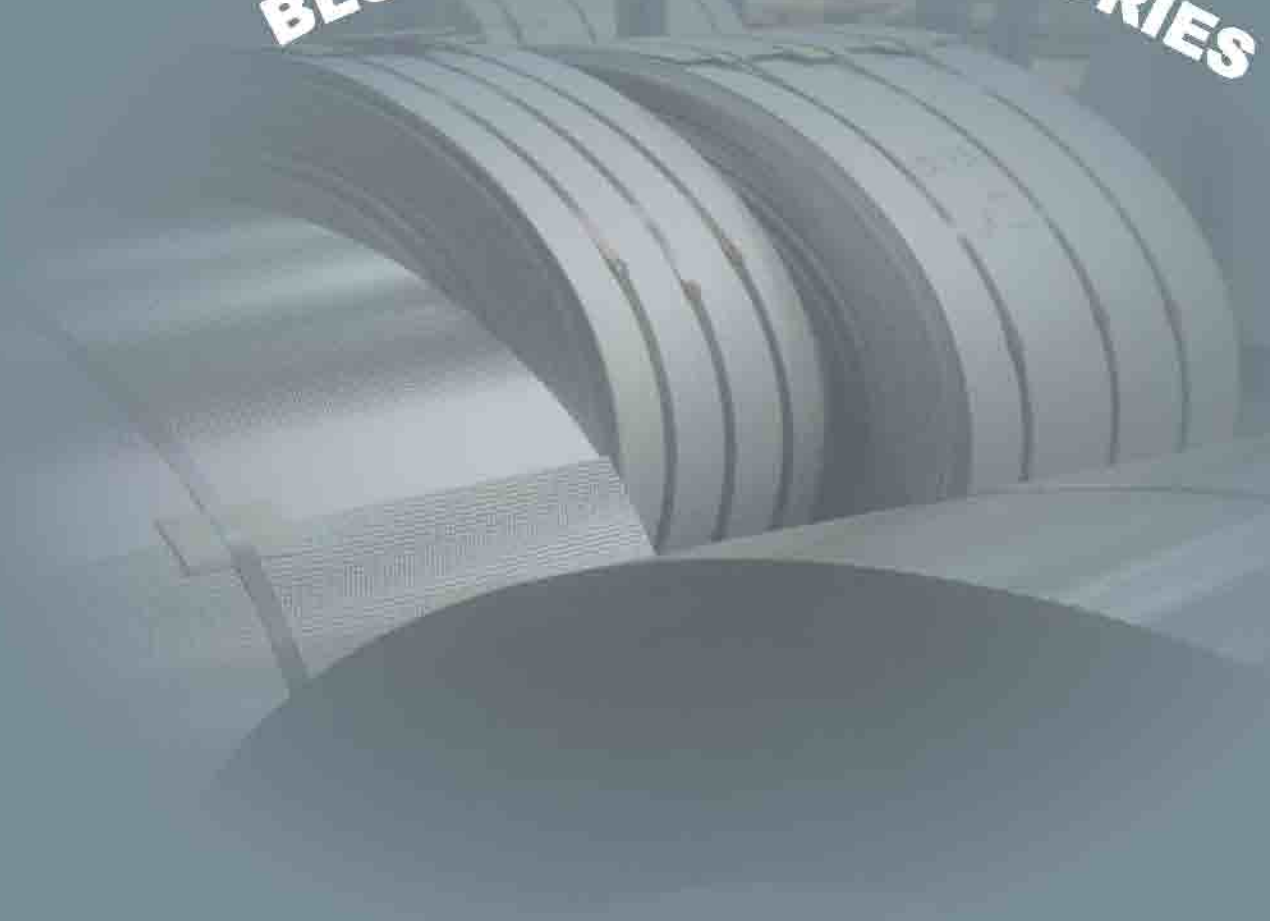

Uni Metal is a product of:
Specialized Factory for Steel Products (SFSP) Jeddah
Tel: +966 2 6374482 Fax: +966 2 6361963
E-mail : sfsp@unitech-ikk.com

SIGMA Factory for Steel Products (SFSP) Dubai
Tel: +971 4 3402637 Fax: +971 4 3402636
E-mail : sigma@unitech-ikk.com

